

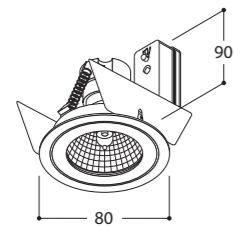









name	CLIO GU10
ref	615529 STAINLESS STEEL
	4100 WHITE
	4110 BLACK
	4120 GREY
	4140 CHROME
	4118 TEXTURED WHITE
	4115 TEXTURED BLACK
	4130 GOLD
	4180 BRONZE
	4190 BRUSHED BRASS



safe distance to object	 - 0,5m - 
lamptype	LED PAR16 (GU10)
fitting	GU10
watt	Max. 10W
voltage or current	230V / 50Hz
symbol	
gear	Mains operation 
ip/class	IP20 
application	Interior - ceiling mounted 
orientability	Downlighter  350°  30°
dimmability	See lamp
weight	 0.2

ACCESSORIES	ref.
- HOUSING BOX 70 TORSION ANODISED	700992
- CONE 51 ANO	700997
- FOCUS RING CHROME	5394
- FOCUS RING GOLD	5395
- FOCUS RING TEXT. WHITE	5396
- FOCUS RING BLACK	5398
- FOCUS RING ANO	5399

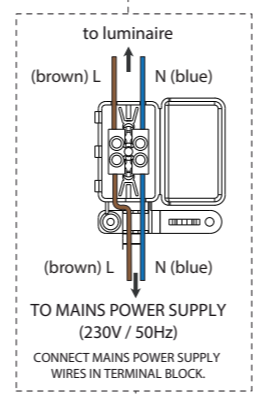
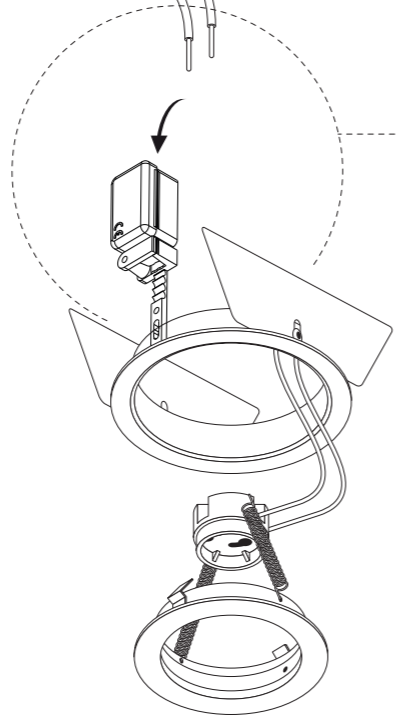
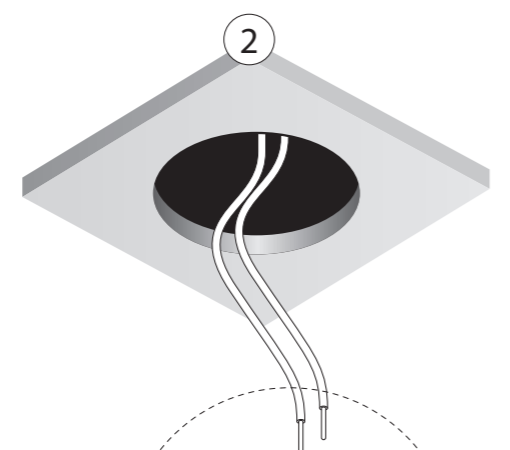
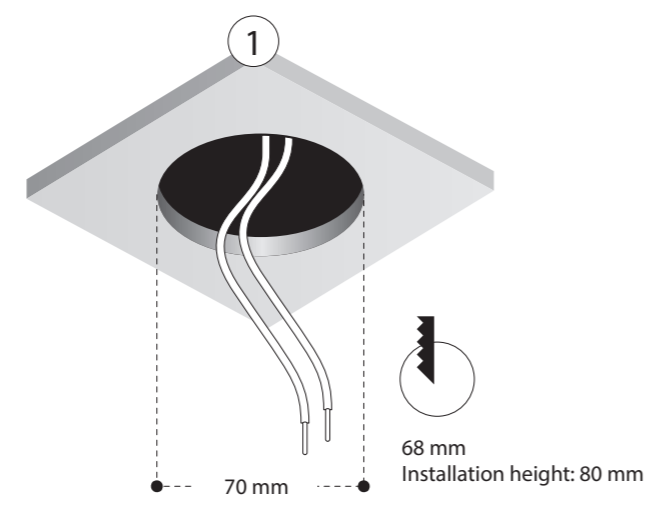

AFTER CONNECTING IN TERMINAL BLOCK, CLOSE CONNECTION BOX & CLOSE CABLE CLAMP BY SCREWING

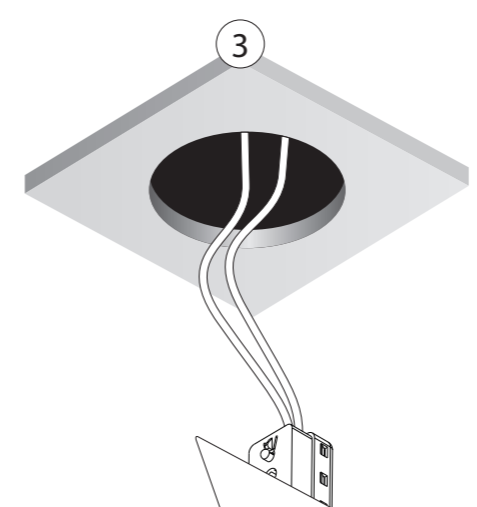
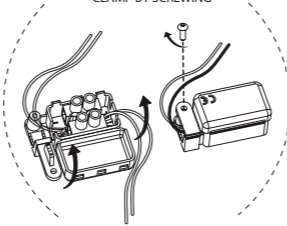

In combination with FOCUS RING

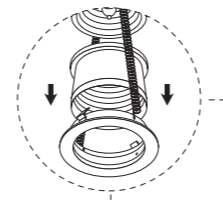

In combination with CONE

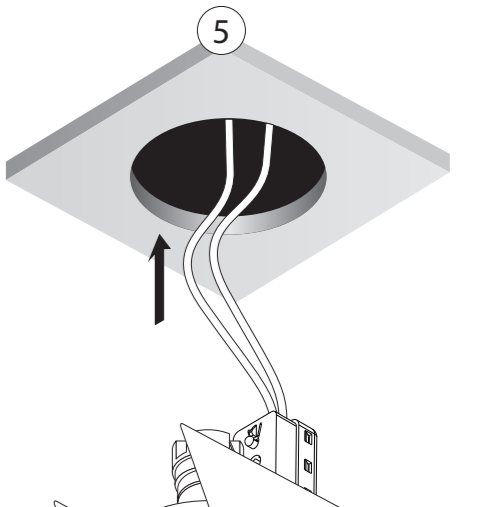
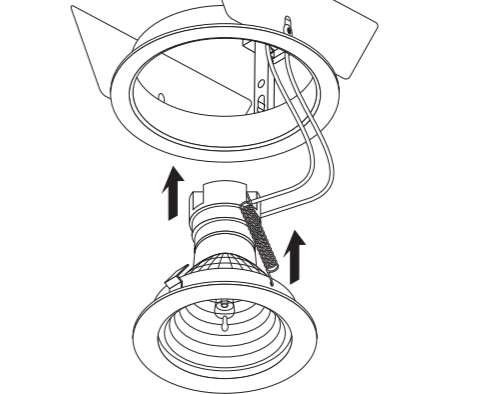
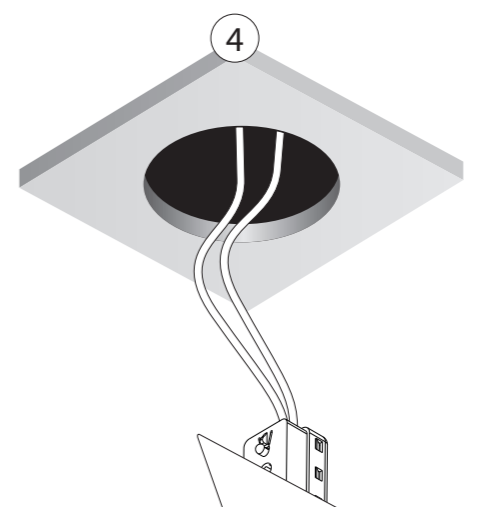
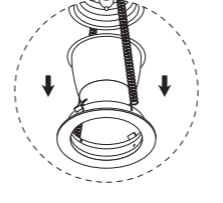

CLIO GU10



CLIO GU10 in combination with CONE



CLIO GU10 in combination with FOCUS RING

INSTRUCTIONS D'INSTALLATION ET D'ENTRETIEN A RESPECTER VIS-A-VIS DE LA GARANTIE.
 1. LE PLACEMENT, LE RACCORDEMENT ET L'ESSAI DE CET APPAREIL DOIVENT TOUJOURS ETRE EFFECTUES PAR UN INSTALLATEUR ELECTRICIEN AGREE.
 2. LES LUMINAIRES DOIVENT ETRE INSTALLEZ, BRANCHES ET TESTES SUIVANT LE REGLEMENT NATIONAL SUR LES INSTALLATIONS ELECTRIQUES EN VIGUEUR. (BELGIQUE, A.R.E.I., ALLEMAGNE: DIN VDE 0100 TEIL 559 A2, ...; CETTE ENUMERATION EST INDICATIVE)
 3. CE MANUEL D'INSTALLATION TECHNIQUE REPRESENTE UNE PARTIE DES CONDITIONS GENERALES DE VENTE DE TAL N.V.
 4. L'ELECTRO-INSTALLATEUR EST RESPONSABLE POUR L'USAGE DE BALLASTS, TRANSFO'S, ... CONFORMES AUX NORMES CE ET EMC EN VIGUEUR.
 5. REMPLACEZ TOUJOURS L'AMPOULE (LES AMPOULES) AVEC PRUDENCE; ELLE(-S) EST (SONT) TRES FRAGILE (-S).
 6. ATTENTION: NE JAMAIS REMPLACER L'AMPOULE AUX MAINS NUES, UTILISEZ TOUJOURS UN CHIFFON !

MONTAGE- UN UNTERHALT INSTRUCTIONS ZU BEACHTEN MIT BEZUG AUF DER GARANTIE.
 1. DIE MONTAGE, DER ANSCHLUSS UND DAS AUSTESTEN DER LEUCHTEN SOLL IMMER VON EINEM ZUSTAENDIGEN ELECTRO-INSTALLATEUR AUSGEFUHRT WERDEN.
 2. DIESE LEUCHTEN MUSSEN INSTALLIERT, ANGESCHLOSSEN UND GETESTET WERDEN NACH DER ALLGEMEINEN NAZIONALEN REGLEMENTATION UBER DIE ELEKTRISCHE INSTALLATIONEN (BELGIEN, A.R.E.I., DEUTSCHLAND: DIN VDE 0100 TEIL 559 A2, ...; DIESE AUFSTELLUNG GESCHICHT DURCH EXEMPLATIVEN TITEL UND KANN NICHT ALS LIMITATIV ODER EXHAUTIV BETRACHTET WERDEN).
 3. DIESE TECHNISCHE GEBRAUCHSANWEISUNG GEHORT ZU DEN ALLGEMEINEN VERKAUFSDINGUNGEN VON TAL N.V.
 4. DER ELECTRO-INSTALLATEUR IST VERANTWORTLICH FUR DAS VERWENDEN VON CE UND EMC GEPRUFTE VORSCHALTGERATE.
 5. DIE LAMPE(-N) SOLL(-EN) IMMER SERH VORSICHTIG ERSAETZT WERDEN.
 6. VORSICHT: MAN DARF NIE DIE LAMPE MIT DEN NACKTEN HAENDEN BERUHREN, MAN SOL IMMER EINEN TUCH BENUTZEN !

INSTALLATIE- EN ONDERHOUDSRICHTLIJNEN m.b.t. FABRIKSGARANTIE.
 1. DE VERBINDINGEN EN HET UITTESTEN VAN DEZE TOESTELLEN DIENEN ALTIJD TE GEBEUREN DOOR EEN ERKEND ELECTRO-INSTALLATEUR.
 2. DEZE VERLICHTINGSTOESTELLEN MOETEN GE'INSTALLEERD, VERBONDEN EN GETEST WORDEN VOLGENS DE NATIONAAL GELDENDE REGLAMENTEN OP DE ELECTRISCHE INSTALLATIES (BELGIE, A.R.E.I., DUITSLAND: DIN VDE 0100 TEIL 559 A2, ...; DEZE OPSOMMING IS LOUWER INFORMATIEF).
 3. DE TECHNISCHE GEBRUIKSAANWIJZING MOET GEZIEN WORDEN ALS ONDERDEEL VAN DE ALGEMENE VERKOOPVOORWAARDEN VAN TAL N.V.
 4. DE ELECTRO-INSTALLATEUR IS VERANTWOORDELIJK VOOR HET GEBRUIKEN VAN VOORSCHAKELAPPARATUUR DIE VOLDOET AAN DE GELDENDE CE EN EMC NORMEN.
 5. VERVANG DE LAMP (-EN) ALTIJD MET DE GROOTSTE ZORG, ZE IS (ZIJN) UITERST BREEKBAAR.
 6. OPGEPAST: PLAATS NOOIT DE LAMP MET BLOTE HANDEN, GEBRUIK ALTIJD EEN DOEK !

INSTALLATION AND MAINTENANCE INSTRUCTIONS IN VIEW OF THE MANUFACTURER'S GUARANTEE.
 1. THE CONNECTION AND TESTING OF THE DEVICES SHOULD ALWAYS BE PERFORMED BY A RECOGNIZED ELECTRICIAN.
 2. THESE LIGHTING DEVICES NEED TO BE INSTALLED, CONNECTED AND TESTED FOLLOWING THE OFFICIAL NATIONAL INSTRUCTION GUIDE FOR ELECTRICAL INSTALLATIONS (BELGIUM, A.R.E.I., GERMANY: DIN VDE 0100 TEIL 559 A2, ...; THIS ENUMERATION IS JUST AN INDICATION)
 3. THIS TECHNICAL ENCLOSURE NEEDS TO BE ADDED TO THE GENERAL SALES CONDITION OF THE TAL N.V.
 4. THE ELECTRO TECHNICIAN IS RESPONSABLE TO USE BALLASTS, TRANSFORMERS, ... WHICH MEET THE VALID CE AND EMC RULES.
 5. ALWAYS REPLACE THE LAMP (-S) WITH UTMOST CAUTIONSNESS, THE LAMP (-S) IS (ARE) VERY FRAGILE.
 6. ATTENTION: NEVER REPLACE THE LAMP WITH BARE HANDS, ALWAYS USE A CLOTH !